



Part Number 30-5142

1000 cc/min Water/Methanol Injection Flow Gauge

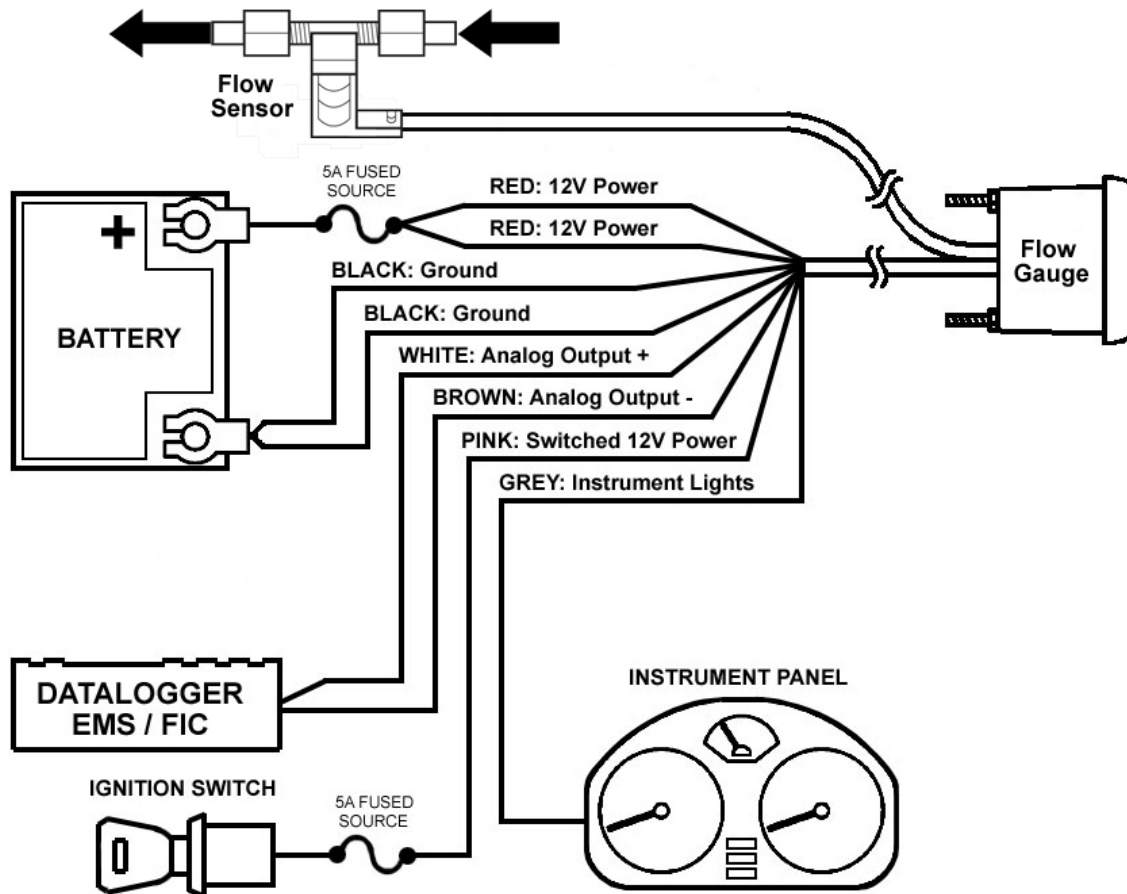

Figure 1. Wiring Schematic

This product is legal in California for racing vehicles only and should never be used on public highways.

AEM Water/Methanol Injection Flow Gauge Parts

- 1 x 35-5142(B/W) Flow Gauge Assembly
- 1 x 35-2126 Flow Sensor with Fittings
- 1 x 35-4302 Install Kit (6 Butt Connectors)
- 1 x 10-5142 Installation Instructions
- 1 x 35-3411 8-Pin Power Harness
- 1 x 35-3415 3-Pin Sensor Harness
- 1 x 35-8529S Silver Bezel
- 1 x 35-8441 Rubber Band

AEM Performance Electronics
 2205 126th Street Unit A, Hawthorne, CA. 90250
 Phone: (310) 484-2322 Fax: (310) 484-0152
<http://www.aempower.com>
 Instruction Part Number: 10-5142 Rev 01
 © 2009 AEM Performance Electronics

INSTALLATION

1. Disconnect the negative battery cable.
2. Secure the gauge in a 2 1/16" (52MM) mounting hole with the supplied bracket. Use the supplied rubber band as a spacer around the gauge if it fits loosely into its mounting hole.
3. Plug the 8-wire power harness into the mating connector on the back of the gauge and connect the wires as shown in Figure 1. The power harness connector can only be inserted one way.
4. Install flow sensor as close as practically possible to final injection point. Verify that arrow on sensor points in the direction of flow. ****NOTE****: It is highly recommended that the **AEM Water/Methanol Injection Filter (AEM part# 30-3003)** be used in conjunction with this flow gauge. Using a filter will maximize the performance and longevity of your flow sensor as well as your entire injection system.
5. Plug the 3-wire sensor harness into the mating connector on the back of the gauge. Insert the sensor harness connector so the two locating tabs point down.

RED - Connect **BOTH** RED wires to a constant 12 volt power source utilizing a 5A fuse.

BLACK – Connect **BOTH** BLACK wires to a clean power ground.

PINK – Connect to a switched 12 volt power source utilizing a 5A fuse.

GREY - Connect to instrument lighting circuit supply voltage.

*WHITE - Connect to Analog + Input.

*BROWN - Connect to Analog – input. (Must be connected if Analog + is used)

**Optional – only needed if using the available differential analog output*

Wiring notes:

RED - When wired as shown above, the gauge will park the needle against the needle stop upon powering down. Alternatively, both RED wires can be connected to the same location as the PINK wire. With both RED wires and the PINK wire connected to the same switched power, the needle will remain at its current position upon powering down. For both power connection methods, the needle will rotate to the parked position before rotating to the value of the current operating condition upon powering up.

GREY – The GREY wire is used to control the lighting intensity of the gauge. Maximum lighting intensity is achieved when the GREY wire is connected to 12 volts. Minimum lighting intensity is achieved when the GREY wire is not connected. The instrumentation illumination on many vehicles is controlled by varying the supply voltage to the instrument panel lights. When the GREY wire is connected to the instrument panel supply voltage, the intensity of the gauge is controlled by the dimmer switch on the dash.

WHITE – The WHITE wire should be connected to the Analog + input on the AEM EMS or the analog + input on a similar device.

BROWN – The BROWN wire should be connected to the Analog – input. If the EMS or similar device does not have a – input, the BROWN wire should be connected to a sensor ground. If no sensor ground is available, the BROWN wire should be connected to a power ground. **Note: The BROWN wire must be connected in order to get correct readings from the analog output.**

Changing the Bezel

The AEM Water/Injection Flow Gauge comes with the black bezel installed. However, a silver bezel is also included in the gauge kit. To change the bezel, orient the gauge so you are looking at the faceplate. Rotate the bezel counter-clockwise to unscrew it from the gauge cup. The bezel, lens, and rubber spacer are all removable. Reassemble the gauge as shown below in Figure 3. Note: When reassembling the gauge, it may be necessary to apply a light amount of pressure on the lens and spacer to keep the faceplate from rotating when reinstalling the bezel. **Do not over tighten the bezel when reassembling the gauge.**

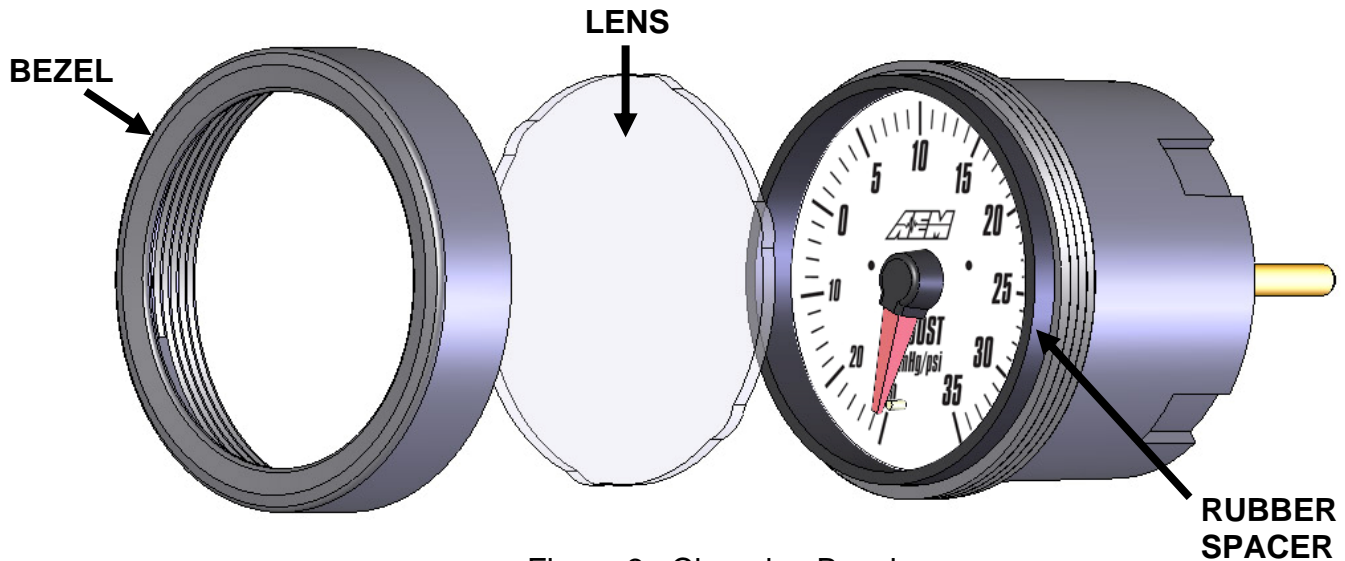

Figure 3. Changing Bezels

Backlighting

The AEM Water/Methanol Injection Flow Gauge has 7 different backlight colors available to the end user, which closely match some of the more common factory dash panels: white, blue, green, red, orange, light blue, and aqua. To change the backlight color, rotate the backlighting switch using a small precision style screwdriver. The backlight switch is accessed through the small hole in the back of the gauge.

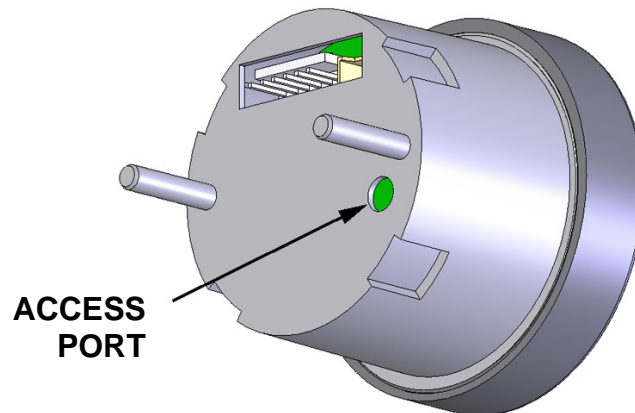

Figure 4. Backlighting Adjustment

Status Lights

The AEM Flow Gauge has two status lights (see Figure 4) that indicate when a high flow condition exists. The right status light flashes once and then repeats if flow is 1250 cc/min or more. This can be indicative of either a controlled flow rate that is beyond the range of the gauge or a slight leak in the system. Both status lights flash four times and then repeat if flow is 2000 cc/min or more. This can be indicative of an uncontrolled open line condition, such as a major leak or broken connection.



Figure 4. Illuminated Status Lights

Analog Output

The analog output from the AEM Water/Methanol Injection Flow gauge is a linear dc voltage signal that varies from **0.5 vdc at 0 cc/min flow to 4.5 vdc at 1000 cc/min flow**. The signal is used for sending information to a data logger or an engine management system like the AEM EMS or F/IC. The transfer functions for the analog output are listed below in cc/min and gal/hr.

$$\text{Flow (cc/min)} = 250 * \text{Voltage} - 125$$

For example, if the output voltage is 2.5 volts, the flow rate is 500 cc/min.

$$250 * 2.50 - 125 = 500 \text{ cc/min}$$

$$\text{Flow (gal/hr)} = 3.96 * \text{Voltage} - 1.98$$

For example, if the output voltage is 2.5 volts, the flow rate is 7.93 gal/hr.

$$3.96 * \text{Voltage} - 1.98 = 7.93 \text{ gal/hr}$$

A list of output voltages and corresponding flow rates is shown below in Table 1.

NOTE: The two overflow conditions mentioned above in **Status Lights** have two specific voltage outputs as listed below in bold.

Voltage	cc/min	gal/hr
0.50	0	0.00
0.75	63	0.99
1.00	125	1.98
1.25	188	2.97
1.50	250	3.96
1.75	313	4.95
2.00	375	5.94
2.25	438	6.93
2.50	500	7.93
2.75	563	8.92
3.00	625	9.91
3.25	688	10.90
3.50	750	11.89
3.75	813	12.88
4.00	875	13.87
4.25	938	14.86
4.50	1000	15.85
4.65	1250	19.81
4.85	2000	31.70

Table 1. Analog Calibrations

Connector Pinouts

The pinouts for the 3-pin sensor harness and 8-pin power harness are provided below in Figure 6.

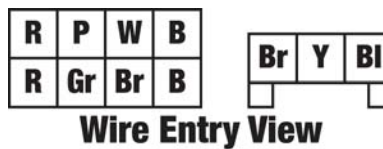

Figure 6. Harness Pinouts

Specifications

Gauge

Supply Current	0.1 A
Differential Analog Outputs	1
Measuring Range	0-1000 cc/min 0-15.85 gal/hr
Operating Voltage (nominal)	8.5-15 volts dc
Harness & Connector Temp Limit:	105C

Notes

The sensor is a precision pressure measuring device and should not be subject to mechanical or thermal shock or it may be damaged.

If further tuning help is needed be sure to visit the video gallery or performance electronics forum at www.aempower.com for comprehensive instructional videos and information.

Replacement Components

35-3411 8-Pin Power Harness
35-3415 3-Pin Sensor Harness
35-2126 Flow Sensor

Important Safety Notice Regarding Methanol

AEM *strongly* recommends that users never exceed a 50% methanol concentration when using any AEM Water Methanol system or component.

All AEM Water/Meth injection systems and components (pump, lines, fittings, filter, flow sensor, tank, and nozzles) are 100% chemically compatible with methanol. However, for safety reasons we strongly recommend that users never use more than a 50% methanol concentration in our systems.

Methanol is a toxic and highly flammable chemical. 100% Methanol ignites easily and burns vigorously with an almost undetectable flame. Methanol can be absorbed through the skin and even small amounts can cause blindness or even death. Using this fluid at high pressures, without dilution, in an under-hood environment with nylon lines and push-to-connect fittings is very unsafe. The performance advantages of using greater than 50% methanol concentrations are small, if they exist at all. However, the safety issues are very real and far out weigh any perceived benefit of running high concentrations of methanol.

Note: AEM holds no responsibility for any engine damage or personal injury that results from the misuse of this product, including but not limited to injury or death caused by the mishandling of methanol.

12 MONTH LIMITED WARRANTY

Advanced Engine Management Inc. warrants to the consumer that all AEM High Performance products will be free from defects in material and workmanship for a period of twelve (12) months from date of the original purchase. Products that fail within this 12-month warranty period will be repaired or replaced at AEM's option, when determined by AEM that the product failed due to defects in material or workmanship. This warranty is limited to the repair or replacement of the AEM part. In no event shall this warranty exceed the original purchase price of the AEM part nor shall AEM be responsible for special, incidental or consequential damages or cost incurred due to the failure of this product. Warranty claims to AEM must be transportation prepaid and accompanied with dated proof of purchase. This warranty applies only to the original purchaser of product and is non-transferable. All implied warranties shall be limited in duration to the said 12 month warranty period. Improper use or installation, accident, abuse, unauthorized repairs or alterations voids this warranty. AEM disclaims any liability for consequential damages due to breach of any written or implied warranty on all products manufactured by AEM. Warranty returns will only be accepted by AEM when accompanied by a valid Return Goods Authorization (RGA) number. Product must be received by AEM within 30 days of the date the RGA is issued.

Please note that before AEM can issue an RGA for any product, it is first necessary for the installer or end user to contact the AEM Performance Electronics tech line at 1-800-423-0046 to discuss the problem. Most issues can be resolved over the phone. Under no circumstances should a system be returned or a RGA requested before the above process transpires.

Need additional help? Contact the AEM Performance Electronics tech department at 1-800-423-0046 or tech@aempower.com, or visit the AEM Performance Electronics forum at <http://forum.aempower.com/forum/>